

PZ 113E User Manual

E-802 Servo-Controller Submodule

Release: 1.4.0 Date: 2004-09-16

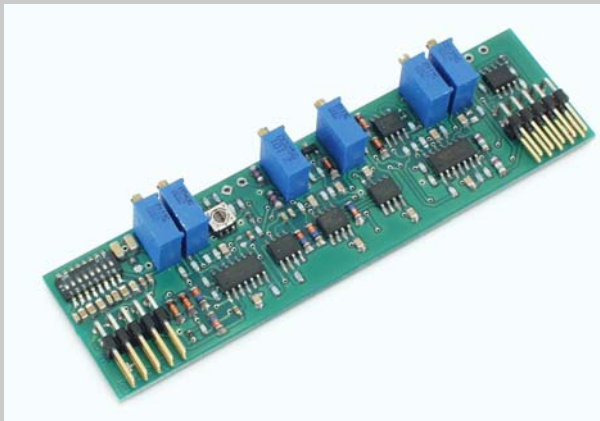

This document describes the following Product(s):

- **E-802.50**
Servo-Control Submodules
- **E-802.51**
Servo-Control Submodules
- **E-802.52**
Servo-Control Submodules
- **E-802.55**
Servo-Control Submodules

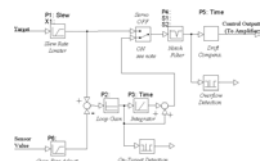
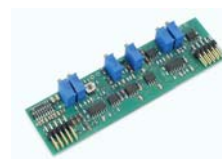

Table of Contents

| | | |
|----------|--|-----------|
| 0 | Safety Precautions | 3 |
| 1 | Introduction..... | 4 |
| 1.1 | Functionality..... | 4 |
| 1.2 | Model Summary..... | 5 |
| 2 | E-802.55 | 6 |
| 2.1 | Component Locations | 6 |
| 2.2 | Adjustment Controls..... | 6 |
| 2.3 | Block Diagram..... | 7 |
| 2.4 | Notch Filter Settings..... | 7 |
| 2.4.1 | Range | 7 |
| 2.4.2 | Damping..... | 8 |
| 2.5 | Voltage Ranges and Over-Voltage Recognition Settings | 8 |
| 2.6 | Test Points | 9 |
| 2.7 | Pinouts | 10 |
| 2.8 | Servo-Loop Calibration | 11 |
| 2.8.1 | Equipment Needed for Calibration..... | 11 |
| 2.8.2 | Preparations..... | 11 |
| 2.8.3 | Zero-Point Adjustment | 12 |
| 2.8.4 | Static Gain Adjustment | 12 |
| 2.9 | Dynamic Calibration..... | 13 |
| 2.9.1 | Finding Resonant Frequency and Setting Notch Filter | 13 |
| 2.9.2 | Step Response Optimization (Empirical Method) | 13 |
| 2.9.3 | Step-Response Optimization (Calculation Method) | 15 |
| 2.9.4 | Sizing Components..... | 16 |
| 2.9.5 | Applying Calculated Values in the Circuit | 16 |
| 3 | E-802.50, E-802.51, E-802.52 | 17 |
| 3.1 | E-802.50 Board Description..... | 17 |
| 3.1.1 | Component Locations | 17 |
| 3.1.2 | Adjustment Controls..... | 17 |
| 3.1.3 | Block Diagram..... | 17 |
| 3.1.4 | Notch Filter Setting | 17 |
| 3.2 | E-802.51 / E-802.52 Board Description | 18 |
| 3.2.1 | Component Locations | 18 |
| 3.2.2 | Adjustment Controls..... | 18 |
| 3.2.3 | Block Diagram..... | 18 |

| | | |
|-------|---|----|
| 3.2.4 | Notch Filter Settings..... | 18 |
| 3.3 | Notch Filter Range Extension Component Tables..... | 19 |
| 3.3.1 | E-802.50 and E-802.51..... | 19 |
| 3.3.2 | E-802.52..... | 19 |
| 3.4 | Voltage Ranges and Over-Voltage Recognition Settings..... | 20 |
| 3.5 | Additional Adjustment and Test Points..... | 20 |
| 3.6 | Pinouts..... | 23 |
| 3.7 | Servo-Loop Calibration..... | 24 |
| 3.7.1 | Equipment Needed for Calibration..... | 24 |
| 3.7.2 | Preparations..... | 24 |
| 3.7.3 | Zero-Point Adjustment..... | 25 |
| 3.7.4 | Static Gain Adjustment..... | 25 |
| 3.8 | Dynamic Calibration..... | 26 |
| 3.8.1 | Finding Resonant Frequency and Setting Notch Filter..... | 26 |
| 3.8.2 | Step Response Optimization (Empirical Method)..... | 26 |
| 3.8.3 | Step-Response Optimization (Calculation Method)..... | 28 |
| 3.8.4 | Sizing Components..... | 28 |
| 3.8.5 | Applying Calculated Values in the Circuit..... | 28 |

© Copyright 2004 by Physik Instrumente (PI) GmbH & Co. KG

Release: 1.4.0

File:E-802UserPZ113E140.doc, 1120256 Bytes

0 Safety Precautions

CAUTION

E-802 submodule boards are ESD-sensitive (electrostatic discharge sensitive) devices. Observe all precautions against static charge buildup before handling these devices.

Avoid touching circuit components, pins and PCB traces. Discharge any static charge you may have on your body by briefly touching a conductive, grounded object before you touch any electronic assembly. Pose PCBs only on conductive surfaces, such as ESD-safe transport containers (envelopes, foam). Electronic subassemblies must always be kept and transported/shipped in conductive packaging.

Make sure that no conductive particles of any kind (metallic dust or shavings, broken pencil leads, loose screws) get on the card.

CAUTION

Calibration of the controller the E-802 is a part of is done prior to delivery by the manufacturer.

Do not adjust potentiometers unnecessarily. Only the zero point will have to be realigned from time to time to compensate for temperature changes. Further adjustments are not required as long as system components are not replaced or modified.

Any calibration procedures are to be carried out by qualified authorized personnel only.

CAUTION

Some adjustment elements on the main board of the controller and on E-802 submodules are covered with sealing lacquer. Damage to the seal will void the warranty except in consultation with PI.

1 Introduction

The E-802 is a small add-on printed circuit board (PCB) that processes the control signal for the power amplifier driving piezoelectric translators. Slew rate limitation, notch filter and servo-control loop are all implemented on the E-802.



E-802.55 servo-control submodule

1.1 Functionality

The servo-loop logic compares the control voltage input and the position sensor signal to generate the power amplifier input control signal. An analog proportional-integral (P-I) algorithm is used. Slew rate limitation insures that the output signal slope does not exceed the following capability of the power amplifier. The notch filter is used to damp out oscillation at the resonant frequency of the mechanics.

In summary:

- Slew rate limitation of output signals can be set within the range of 15 V/ms up to 1500 V/ms. Note that these values are only valid for the slew-rate-limitation circuit. The values for the complete system are lower due to limitations given by amplifier, notchfilter etc. (1 V/ms to 500 V/ms).
- P-I control performance, with individual setting of P- and I-terms.
- Optional notch filter allows suppression of mechanical resonances. The filter frequency and quality can be adjusted by trim potentiometers.
- Servo function can be enabled/disabled via TTL signals (low=servo ON, high=servo OFF).

Excellent long-term stability is accomplished by using exclusively low-tolerance / low-drift components. Residual errors in the range of 0.05% can be compensated with additional trimming components.

The location of the E-802 on the board on which it is installed is indicated in the User Manual for that board (e.g. the E-621). This manual describes those functions and procedures specific to the E-802.

1.2 Model Summary

Note that only the E-802.55 revision ADC or higher, which is described in the separate manual PZ 150E, is in production.

This document (PZ 113E) describes the earlier E-802.55 versions and the versions E-802.50, E-802.51 and E-802.52, which are pin-compatible to E-802.55 and may still be encountered in some equipment.

- **E-802.50** first version
- **E-802.51s** have an additional adjustment potentiometer (P407) for fine adjustment of the monitor output.
- **E-802.52s** have an additional potentiometer for fine adjustment of dynamic properties. An additional time constant allows compensating the position error caused by PZT creeping effects. Settling times can be reduced significantly by these procedures. With this module, notch Q-factor adjustment is no longer required.
- **E-802.55**: in contrast to earlier versions, E-802.55s leave notch filter and slew rate functions turned on when servo-control is turned off. They also have a mini DIP switch for selection of notch filter frequency ranges, so that component replacement is not necessary. For revision ADC or higher see User Manual PZ 150E.

The following sections describe version-specific features. Be sure to locate the section that corresponds to the version you have.

2 E-802.55

The 802.55 is currently replacing the earlier versions. With the E-802.55 the notch filter and slew rate limiter are also active even when the servo-mode TTL input line is at the servo-OFF level (open-loop operation).

Note: In open-loop mode, the gain may vary by a value in the range of -3% to +6% depending on the setting of P5 (drift compensation potentiometer, see figure below). By default P5 is preset to its mid position.

2.1 Component Locations

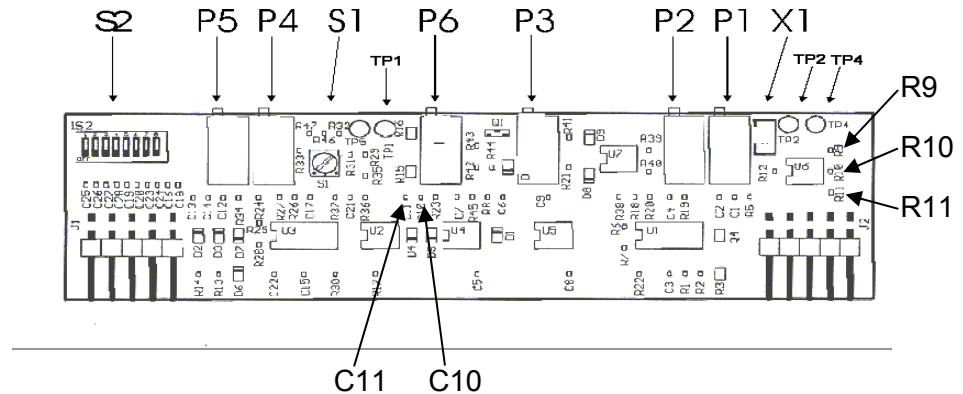

For pinouts see p. 10.

For element description see:

P1 to P6, S1, S2, X1 see below

R9 to R11 on p. 8

TP1, TP2 and TP4 on p. 9

C10, C11 on p. 16

2.2 Adjustment Controls

| | |
|----|------------------------------------|
| P1 | Slew Rate Limitation |
| P2 | Loop Gain (P-Term) |
| P3 | Integration Time Constant (I-Term) |
| P4 | Notch Frequency |
| P5 | Drift Compensation |
| P6 | Sensor Gain Fine Adjust |
| X1 | Slew Rate Range |
| S1 | Notch Filter Damping |
| S2 | Notch Filter Range |

2.3 Block Diagram

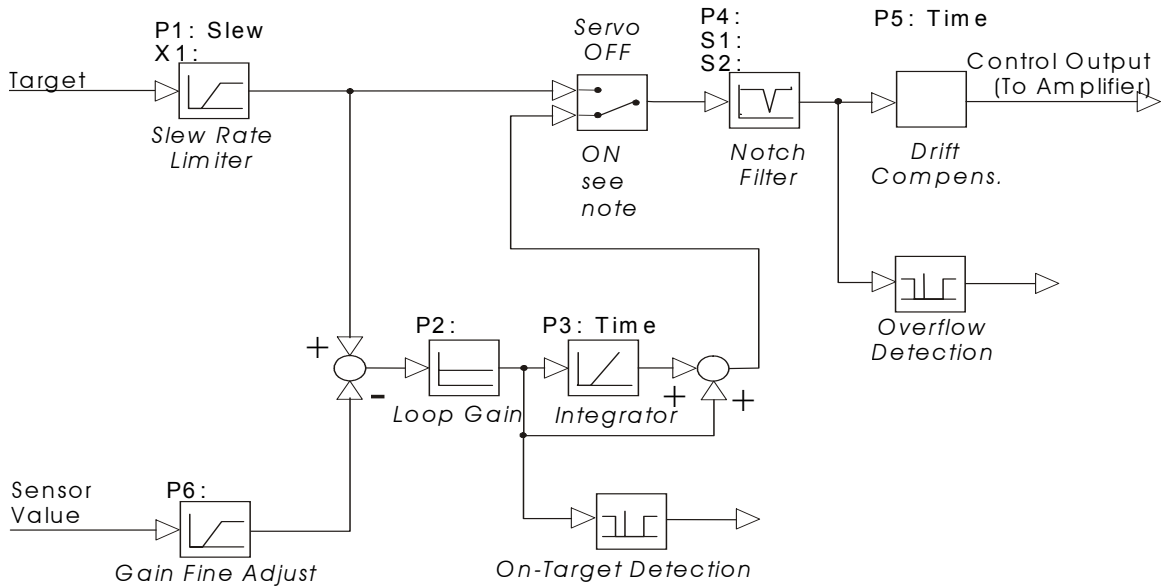

E-802.55 Block Diagram

Note: The servo ON-OFF “switch” is controlled by electrical signals from the board on which the submodule is installed.

2.4 Notch Filter Settings

The frequencies within a frequency range can be set with potentiometer P4. Alternate/extended frequency ranges are available with the mini DIP switches (S2) as shown in the table below (contact PI for latest information on possible changes):

2.4.1 Range

| Range Number | Mini-DIP Switch Block S2 (switch slider shown in black) | P4-Min. Notch Frequency in Hz | P4-Max. Notch Frequency in Hz |
|-----------------------|--|-------------------------------|-------------------------------|
| 1 | ON OFF | 40 | 130 |
| 2 | ON OFF | 120 | 380 |
| 3 | ON OFF | 340 | 1100 |
| 4 | ON OFF | 950 | 3100 |
| 5* (all switches OFF) | ON OFF | 2900 | 9300 |

2.4.2 Damping

The damping setting is with S1, settable with a small screwdriver:

| | | | |
|-----------------------------------|--------------|--------------|--------------|
| | | | |
| <p>S1 Setting (circle)</p> | | | |
| <p>Value</p> | <p>20 dB</p> | <p>20 dB</p> | <p>25 dB</p> |

2.5 Voltage Ranges and Over-Voltage Recognition Settings

| Nominal Voltage Range / V | Actual Voltage Range / V | R9 | R10 | R11 |
|---------------------------|--------------------------|---------|---------|---------|
| NV, 0 to 100 | -20 to +120 | 3.01 kΩ | 14.0 kΩ | 13.0 kΩ |
| HI, -1000 to 0 | -1120 to -3 | 4.02 kΩ | 11.3 kΩ | 14.7 kΩ |
| HII, -750 to +250 | -790 to +265 | 7.15 kΩ | 10.5 kΩ | 12.4 kΩ |
| HIII, -500 to +500 | -560 to +560 | 9.53 kΩ | 11.0 kΩ | 9.53 kΩ |
| HIV, -250 to +750 | -265 to +790 | 12.4 kΩ | 10.5 kΩ | 7.15 kΩ |
| HV, 0 to +1000 | +3 to +1120 | 14.7 kΩ | 11.3 kΩ | 4.02 kΩ |

Table 1. E-802.55 component substitution chart for voltage ranges and over-voltage recognition

More precise adjustments are not possible here, as the reference voltage is derived from the operating voltage, which can vary by about 1% from the nominal value. The same tolerance has to be taken into account regarding over-voltage recognition.

2.6 Test Points

Test point TP1, Slew Rate; Servo ON and OFF (for location see figure on p. 6)

set required rise time using P1, watch PZT voltage and sensor values

Typical curve at positive input step:

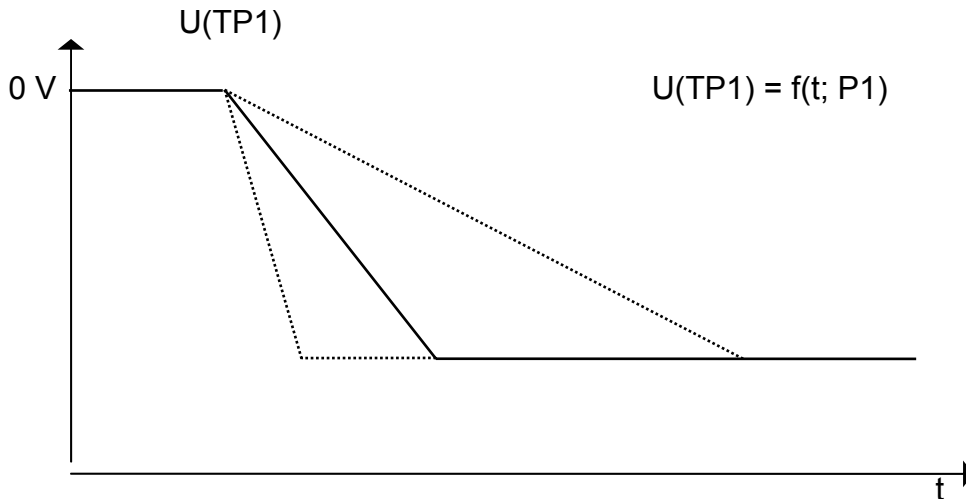

After the rise time the input voltage must be reached. For fast applications remove jumper X1.

Note: This stage inverts the input signal.

Test point TP2, comparison point, servoON only

After settling, this voltage must be zero.

Note: A permanent voltage indicates that somewhere in the servo-loop there is an undesirable limitation. (amplifier, PZT, sensor or controller)

Typical curve at positive input signal step.

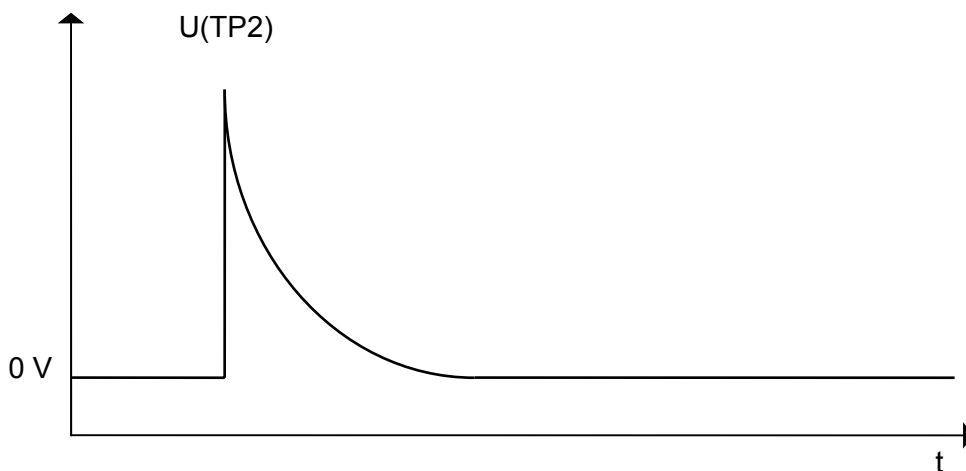

Test point TP4, Notch, Servo ON only

Time response at input step depends on setting, example:

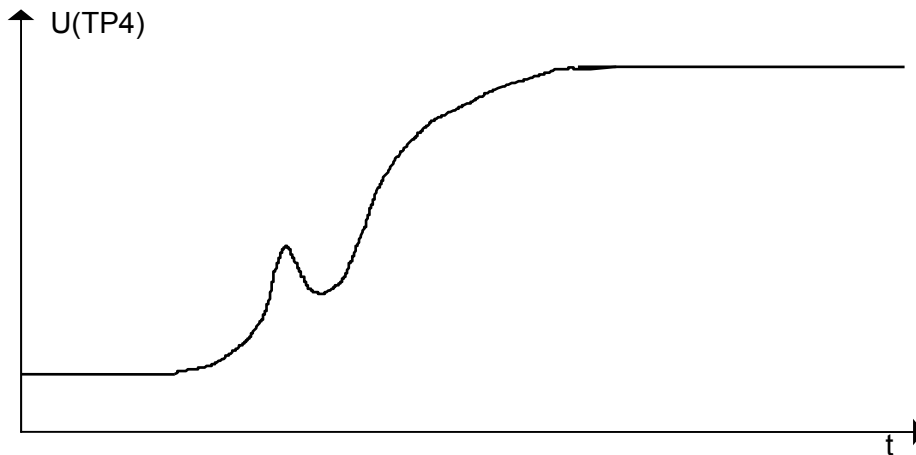

Test Criterion: Final value equals input signal

2.7 Pinouts

The connectors J1 and J2 of all E-802 versions are pin-compatible, except as noted.

Connector J1

| Pin | Signal | Meaning |
|-----|--------------|--|
| 1 | LED_K | Overflow LED, cathode (-), normally 0 V = overflow |
| 2 | LED_A | Overflow LED, anode (+), normally always +5 V |
| 3 | GND | 0 V |
| 4 | GND | 0 V |
| 5 | VC/EC | Set servo OFF/ON |
| 6 | VC/EC | Set servo OFF/ON |
| 7 | Actual value | Current position (0-10 V) |
| 8 | Actual value | Current position (0-10V) |
| 9 | VEE | -15 V |
| 10 | VEE | -15 V |

Connector J2

| Pin | Signal | Meaning |
|-----|----------|--|
| 1 | CTRL_OUT | Servo-controlled output, -2 to +12 V |
| 2 | ONT | On target (within $\pm 0.19\%$ of range of target), TTL active-low |
| 3 | COMMAND | Target, 0-10 V |
| 4 | OFL | Overflow, TTL, active-low |
| 5 | VCC | +15 V |
| 6 | VCC | +15 V |
| 7 | VEE | -15 V |
| 8 | VEE | -15 V |
| 9 | GND | 0 V |
| 10 | GND | 0 V |

2.8 Servo-Loop Calibration

Static servo-loop calibration makes it possible to accurately drive the PZT system to absolute positions in closed-loop mode with an external analog control signal ranging from 0 to +10 volts. This signal can either be input directly, or it can be generated by computer-control electronics in the system (e.g. E-816 Computer Interface and Command Interpreter).

Static servo calibration establishes the relationship between a sensor input of 10 V and the voltage necessary to drive the PZT to its nominal expansion.

Dynamic servo-loop calibration optimizes step response and suppresses resonance, overshoot, and oscillation (see section 2.9 beginning on page 13).

Dynamic performance of the PZT system is determined by the maximum output current of the amplifier and by the mechanical properties of the PZT-mechanics like moving mass, damping and resonant frequencies.

In order to match the circuitry and the mechanical characteristics to achieve the desired performance, the system has to be adjusted for both static and dynamic operations.

The full calibration and adjustment procedure includes adjustment of the zero point, sensor gain, slew rate and step response. All these basic adjustments are done in our lab before shipment.

If PI has sufficient information about your application, your PZT system will be shipped ready for operation. Only the zero point will have to be realigned from time to time to compensate for temperature changes. Further adjustments are not required as long as system components are not replaced or modified.

Since open-loop sensor zero and range adjustment does not involve the servo-control module, it is described in detail in the other manuals accompanying this system.

The PZT actuator has to be calibrated in conjunction with the individual device and submodule to which it is connected: both devices then belong together. Replacement of either one or the other requires new calibration run to get the specified system accuracy.

2.8.1 Equipment Needed for Calibration

For adjustment of the zero-point, a voltmeter is required.

Static displacement calibration requires an external expansion gauge with 0.1 μm resolution and a precision voltmeter. A special extension adapter may be required if your installation does not allow access to the potentiometers that need to be adjusted while the unit is in operation.

Dynamic calibration procedures require an oscilloscope (a digital storage oscilloscope is recommended), frequency generator to output square and sine functions from 1 Hz to 1 kHz, an ohmmeter with a range from 0.1 to 100 k-ohm and, depending on the installation, a 32-pin extension adapter board to allow access to the trim potentiometers while the board is in operation.

If the system is set up for computer control, it may be possible to substitute the wave generators, D-to-A and A-to-D converters there for some of the equipment mentioned above.

2.8.2 Preparations

Mount the PZT actuator in exactly the same way and with the same load as during normal operations in the application.

2.8.3 Zero-Point Adjustment

Correct zero-point adjustment allows the PZT to be used within the full displacement range without reaching the output voltage limits of the amplifier.

A proper zero-point calibration ensures that in closed-loop operation the full output voltage swing of the amplifier can be used and prevents overflow conditions.

Procedure:

1. Adjust the sensor zero point while servo mode is OFF as described in the manual for the controller (desktop unit, module or OEM board) on which the E-802.55 is installed.
2. Set servo mode to SERVO ON and make sure that the control input voltage is set to the value (target position) which is to correspond to 0 V PZT operating voltage. Normally this control input voltage value is 0 V¹.
3. Connect a voltmeter to the output socket for the PZT operating voltage.
4. Readjust the PZT operating voltage to 0 V using the ZERO potentiometer.

2.8.4 Static Gain Adjustment

The objective of the static servo-loop adjustment procedure is to ensure that the PZT actuator expands to its nominal expansion when the control signal input is 10 V.

Preparations: An adjustable voltage source from 0 to +10.0000 V and a displacement gauge with 0.1 μm resolution is needed².

Procedure

1. Make sure that any DC-offset is set to zero or disabled (see main board manual).
2. Set SERVO ON mode.
3. Check whether the PZT oscillates. If it does, you can't miss hearing it, and dynamic gain adjustments have to be done prior to continuing with static gain adjustment.
4. Apply 0 V to the CONTROL INPUT.
5. Adjust the external position probe and set the expansion reading to zero.
6. Command a position equal to the nominal expansion (i.e. apply 10 V to the CONTROL INPUT). The external gauge should show the PZT at nominal expansion and the sensor monitor output should be 10 V.
7. To adjust the sensor monitor output to exactly 10.000 V use the P6 GAIN Fine Adjust potentiometer on the E-802.55 servo submodule.
8. To adjust the expansion without changing the sensor monitor output (servo-control is on!) use the gain adjustment potentiometer on the E-801.x sensor module.

Repeat the last steps several times until stable results are achieved.

¹ In some cases, e.g. with the E-651 controller/amplifier for closed-loop bender actuators, the PZT operating voltage has to be 0 V if the control input voltage is -5 V.

² With bender actuators a non-contact measuring method must be applied.

2.9 Dynamic Calibration

A summary of the equipment needed for calibration can be found in section 2.8.1 on page 11.

2.9.1 Finding Resonant Frequency and Setting Notch Filter

Evaluate the resonant frequency of the actuator while installed at the operation site. For this purpose a square wave is applied to the input with servo-control set to OFF (≈ 10 Hz, 1 Vpp, use DC offset 0.5 V if bipolar).

Connect the sensor monitor output with one channel of the oscilloscope and watch the step response. The resonant frequency of the system can be estimated by the induced oscillations. If, for example, the period of the oscillation is 3 ms, then the resonant frequency is $1/\text{period length}$ or $1/3 \text{ ms} = 0.33 \text{ kHz}$ or 330 Hz.

Based on this frequency, the dimensioning of the notch filter can be found in the table on page 7.

2.9.2 Step Response Optimization (Empirical Method)

Either this method or the calculation method, described in Section 2.9.3, can be used.

Standard Tuning

For dynamic operation, the step response of the mechanical system is important. The amount of damping and overshoot can be optimized by tuning the differential and integral term of the amplifier. Either the empirical or the calculating method can be used.

Procedure

1. Mount the PZT exactly as it will be operated.
2. Set Servo ON.
3. Use a square wave function generator and supply the input with a square wave of 5 Vpp (if bipolar, set DC offset to 2.5 V) and a frequency of 5 to 10 Hz.
4. Connect an oscilloscope to the monitor output.
5. Adjust P2 until resonant frequency becomes apparent.
6. Adjust P4 notch filter frequency until the oscillation amplitude becomes a minimum.
7. Adjust P2 and P3, alternating to optimize step response.

The settling curve seen on the scope could look like one of the following:

Case 1: Large overshoot, unstable

Case 2: Optimal

Case 3: Settling time too long

Sensor Monitor Signal:

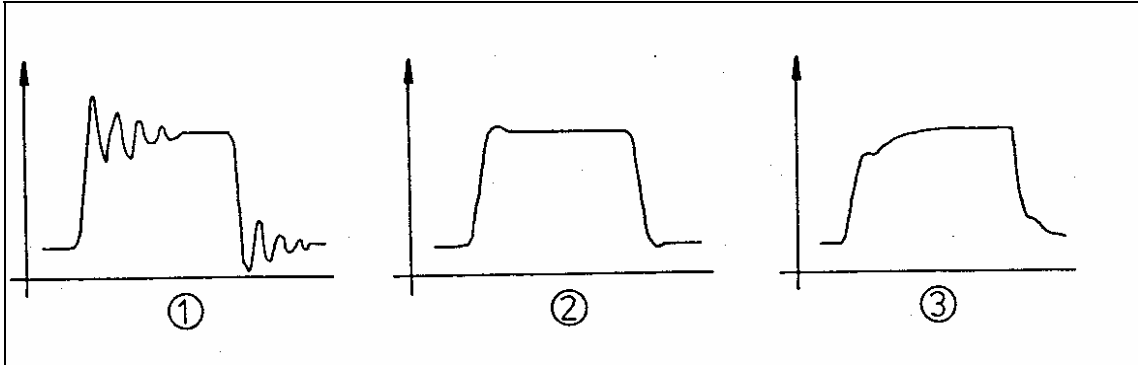

Dwg.: PZTRESP.BMP

Fine Tuning

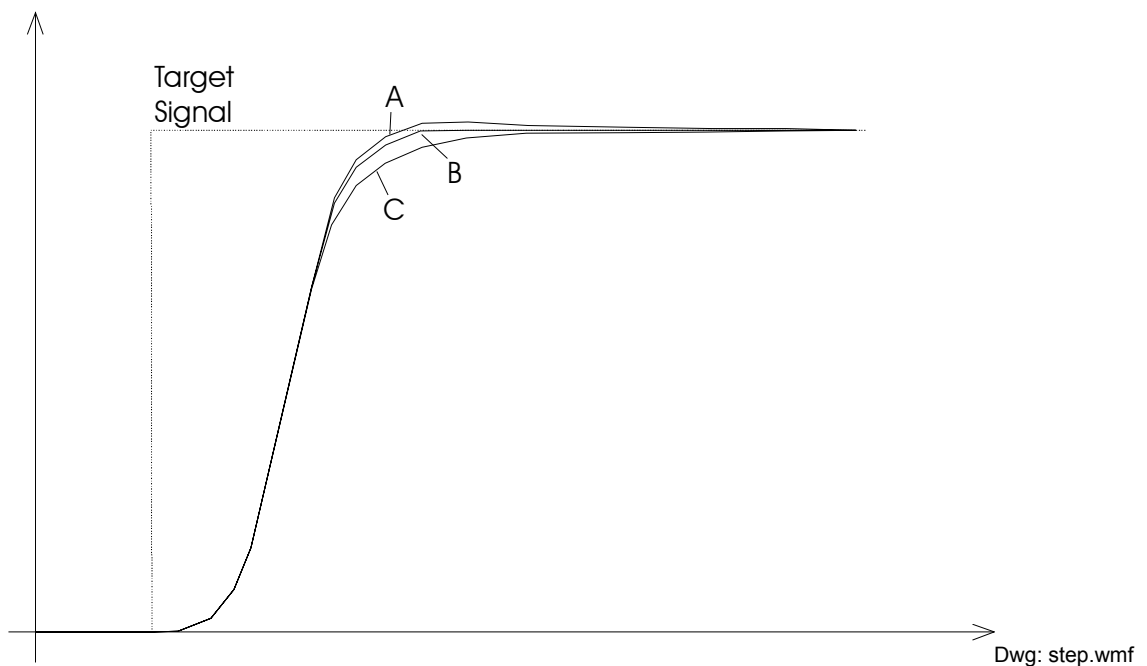

The objective of the drift fine tuning is curve B of the diagram. Because the curve is exaggerated, a high-resolution oscilloscope (12-14 bits) is required as well as a precise voltage generator.

First, adjust the step response without overshoot. Using P5³ (drift compensation potentiometer, for location see figure on p. 6) curve shapes A, B and C can be attained. If the overshoot can not be eliminated by using P5, the loop gain has to be reduced.

The result may be different at rising and falling edges, so a compromise has to be found.

³ : By default P5 is preset to its mid position. In open-loop mode, the gain may vary by a value in the range of -3% to +6% depending on the setting of P5.

2.9.3 Step-Response Optimization (Calculation Method)

Either this method or the empirical method, described in Section 2.9.2, can be used.

Servo-loop parameters depend on each and every component used in the system. Amplifier, PZT actuator and sensor have to be treated as a complete system, and the best way to determine the system servo parameters is the use of a simulation program.

If no simulation program is available, typical assumptions can be made in order to get stable servo parameters—not optimized, but good enough to work with.

Proportional term: $K_p = 0.3$

Integration time: $T_I = \frac{1}{2\pi f_{res}}$

Example: $f_{res} = 330 \text{ Hz} \rightarrow T_I = 0.48 \text{ ms}$

Note: If the PZT resonant frequency is above 1 kHz, the system bandwidth is limited by the amplifier and the sensor. In no case should a higher frequency be used.

2.9.4 Sizing Components

$$P_2 = K_p \cdot 27400\Omega - 470\Omega;$$

$$P_3 = \frac{T_I}{C_{10} + C_{11}} - 470\Omega; [T_I] = s; C_{10} = 22 \cdot 10^{-9} F; C_{11} = 22 \cdot 10^{-9} F;$$

Example: $K_p = 0.3 \quad \rightarrow \quad P_2 = 7.75 \text{ k}\Omega;$
 $T_I = 0.48 \text{ ms} \quad \rightarrow \quad P_3 = 10.44 \text{ k}\Omega;$

2.9.5 Applying Calculated Values in the Circuit

Case 1: If a software simulation run has already determined the optimized values, these values can be set immediately using the corresponding potentiometers.

Case 2: The following procedure has to be used if the servo parameters are derived from arbitrary values:

1. Set potentiometer P1 (slew rate limitation) to CCW hard stop.
2. Set P2 (p-term) to starting value using an ohmmeter.
3. Set P3 (i-term) to a value of 130% of the calculated value (add 30% to the calculated value).
4. Power up the device and set SERVO ON. If you hear oscillation noise, set SERVO OFF immediately. Verify all values you have set.
5. Apply a square wave signal (10 Hz, 10 Vpp, 5 V Offset) to the input.
6. Turn potentiometer P3 (i-term) CW until a significant overshoot can be seen (2 to 5%).
7. Adjust P4 (notch filter) so that resonance effects and overshooting are optimally damped.
8. Depending on the application, set P3 either for optimized settling or to allow an overshoot of 5 to 10 %. The latter choice provides a larger bandwidth.
9. Turn P1 (slew rate limitation) CW until the wobble comes to a minimum without increasing the rise time significantly.
10. Apply a sine wave with variable frequency, 10 Vpp, 5 V offset. Check the sensor reading for amplitude and signal shape starting at 10 Hz up to the resonant frequency. If needed, repeat steps 8 and 9. If the bandwidth is too small, increase the i-term. (This also increases the overshoot amplitude for a step response.) If signal distortions are already noticeable well below the resonant frequency, decrease the i-term.

3 E-802.50, E-802.51, E-802.52

3.1 E-802.50 Board Description

The E-802.50 is no longer in production.

3.1.1 Component Locations

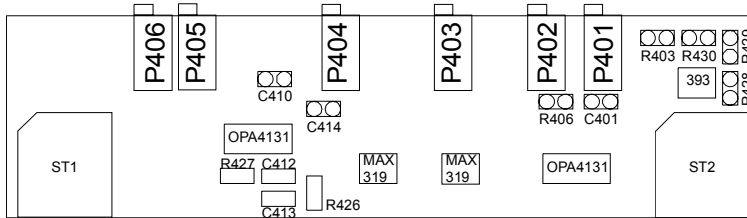

For pinouts see p. 23.

3.1.2 Adjustment Controls

- P401: Slew rate limit setting, must be set to match the amplifier's current-supply capability.
 P402: Proportional term of the servo-control loop (loop gain)
 P403: Integration term of the servo-control loop (i-term)
 P404: Feedforward gain setting of the servo-loop. Not installed as standard.
 P405: Notch filter Q-factor
 P406: Notch filter frequency, must be set to the first resonant frequency of the PZT mechanics. (For range change/extension, see C412-C414)
 C401: Range extension for slew rate (rise time), standard 47 nF
 C410: Range extension for integral term, not installed as standard
 R403: Correction of a positive control deviation, 0 ohms as standard, only on E-802.50
 R406: Correction of a negative control deviation, 0 ohms as standard, only on E-802.50
 R428, R429, R430 Programming of over-voltage limits. See table p. 20.
 C412, C413, C414 Determine available notch filter frequency range. See table p. 19

3.1.3 Block Diagram

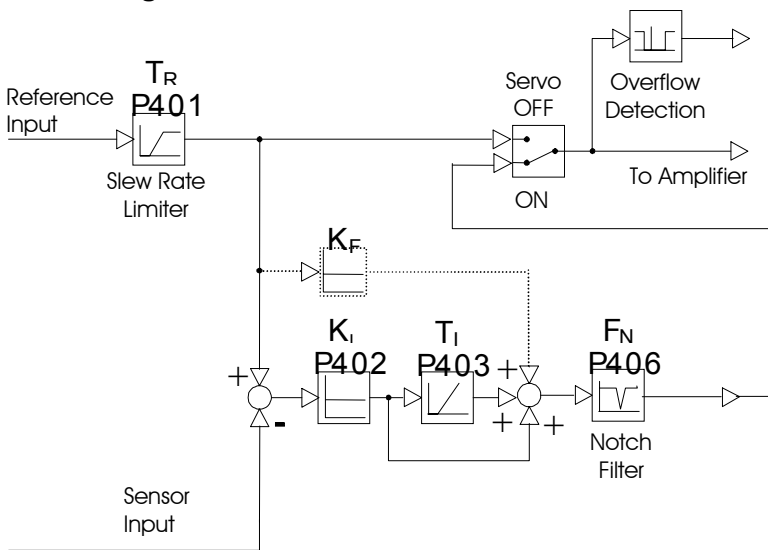

3.1.4 Notch Filter Setting

The frequencies within a frequency range can be set with potentiometer P406.

Alternate/extended frequency ranges can be attained by component substitution. The ranges and component values are given in the table on p. 19.

3.2 E-802.51 / E-802.52 Board Description

3.2.1 Component Locations

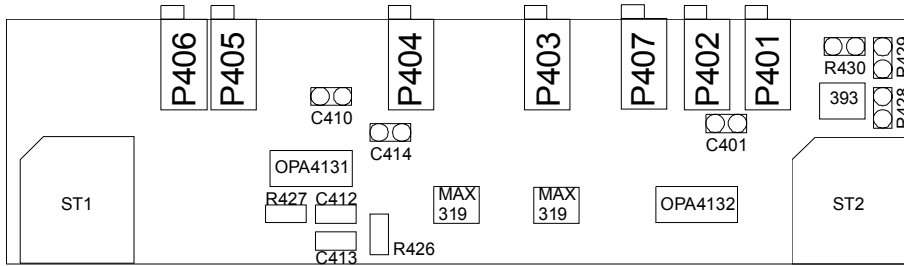

For pinouts see p. 23.

3.2.2 Adjustment Controls

| | | |
|------------------|-------|---|
| P401: | T | Slew rate limit setting, must be set to match the amplifier's current-supply capability. |
| P402: | K | Proportional term of the servo-control loop (loop gain) |
| P403: | T_I | Integration term of the servo-control loop (i-term) |
| P404: | K_F | Feedforward gain setting of the servo-loop. Not installed as standard. |
| P405: | | E-802.51: notch filter Q-factor |
| | T_D | E-802.52: PZT drift compensation, fine adjustment |
| P406: | f_N | Notch filter frequency, must be set to the first resonant frequency of the PZT mechanics. (For range change/extension, see C412-C414) |
| P407 | K_S | Adjustment of output monitor (E-802.52 only) |
| C401: | | Range extension for slew rate (rise time), standard 47 nF |
| C410: | | Range extension for integral term, not installed as standard |
| R428, R429, R430 | | Programming of over-voltage limits. See table p. 20. |
| C412, C413, C414 | | Determines available notch filter frequency range. See tables p. 19. |

3.2.3 Block Diagram

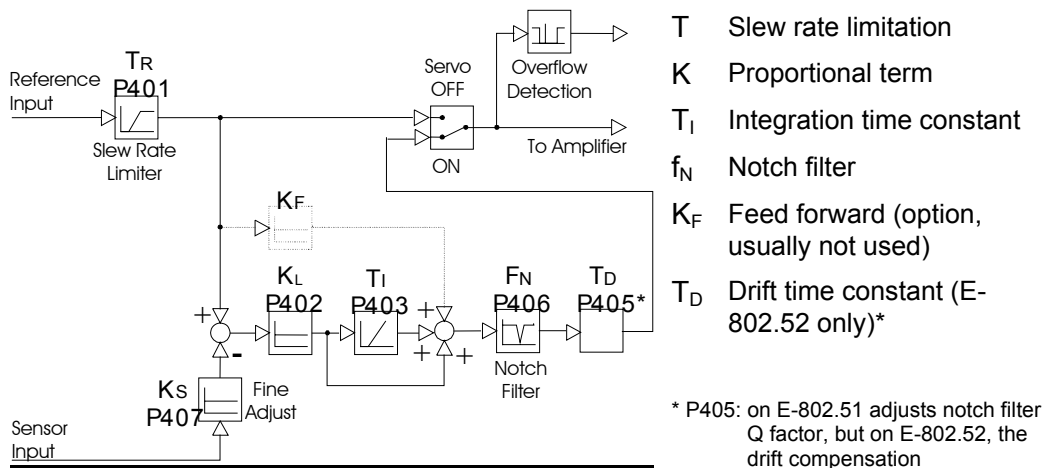

3.2.4 Notch Filter Settings

The frequencies within a frequency range can be set with potentiometer P406. Alternate/extended frequency ranges can be attained by component substitution. The ranges and component values are given in the tables on p. 19.

3.3 Notch Filter Range Extension Component Tables

Versions E-802.50 and E-802.52 require component substitution to obtain different notch filter setting ranges. The frequencies within indicated frequency ranges can be set with potentiometer P406.

3.3.1 E-802.50 and E-802.51

| Frequency Range | | Component Values (E-802.50 and E-802.51) | | | | | | | | | |
|------------------|------------------|--|------|------|------|-----------------|-----------|------|------|------|-----------------|
| | | Damping Options | | | | | | | | | |
| f _{min} | f _{max} | -25 dB | | | | | -20 dB | | | | |
| | | C414+C413 | C412 | R426 | R427 | F ₁₀ | C414+C413 | C412 | R426 | R427 | F ₁₀ |
| Hz | Hz | nF | nF | kΩ | kΩ | Hz ² | nF | nF | kΩ | kΩ | Hz ² |
| 40 | 90 | 100 | 820 | 22 | 22 | 6.57E+5 | 33 | 1500 | 47 | 47 | 8.00E+5 |
| 90 | 220 | 47 | 220 | 22 | 22 | 3.96E+6 | 18+2.2 | 680 | 47 | 47 | 3.92E+6 |
| 190 | 490 | 18 | 150 | 22 | 22 | 2.00E+7 | 6.8+2.2 | 330 | 47 | 47 | 1.81E+7 |
| 300 | 750 | 8.2+2.2 | 100 | 22 | 22 | 5.20E+7 | 3.3+2.2 | 220 | 47 | 47 | 4.45E+7 |
| 610 | 1600 | 3.3+2.2 | 47 | 22 | 22 | 2.08E+8 | 0.56+2.2 | 100 | 47 | 47 | 1.95E+8 |
| 1600 | 4100 | 2.20 | 18 | 22 | 22 | 1.36E+9 | 2.20 | 22 | 47 | 47 | 1.36E+9 |

3.3.2 E-802.52

| Frequency Range | | Component Values (E-802.52) | | | | | |
|------------------|------------------|-----------------------------|------|-----------------|------|--------|----|
| | | C413 | C412 | Damping Options | | | |
| | | | | -25 dB | | -20 dB | |
| f _{min} | f _{max} | R426 | R427 | R426 | R427 | | |
| Hz | Hz | nF | nF | kΩ | kΩ | kΩ | kΩ |
| 38 | 103 | 100 | 100 | 7.5 | 13 | 22 | 27 |
| 80 | 219 | 47 | 47 | 7.5 | 13 | 22 | 27 |
| 171 | 467 | 22 | 22 | 7.5 | 13 | 22 | 27 |
| 377 | 1028 | 10 | 10 | 7.5 | 13 | 22 | 27 |
| 802 | 2188 | 4.7 | 4,7 | 7.5 | 13 | 22 | 27 |
| 1712 | 4674 | 2.2 | 2.2 | 7.5 | 13 | 22 | 27 |

3.4 Voltage Ranges and Over-Voltage Recognition Settings

| Nominal Voltage Range / V | Actual Voltage Range / V | R428 | R429 | R430 |
|---------------------------|--------------------------|-----------------|-----------------|-----------------|
| NV, 0 to 100 | -20 to +120 | 3.01 k Ω | 14.0 k Ω | 13.0 k Ω |
| HI, -1000 to 0 | -1120 to -3 | 4.02 k Ω | 11.3 k Ω | 14.7 k Ω |
| HI1, -750 to +250 | -790 to +265 | 7.15 k Ω | 10.5 k Ω | 12.4 k Ω |
| HI11, -500 to +500 | -560 to +560 | 9.53 k Ω | 11.0 k Ω | 9.53 k Ω |
| HI1V, -250 to +750 | -265 to +790 | 12.4 k Ω | 10.5 k Ω | 7.15 k Ω |
| HV, 0 to +1000 | +3 to +1120 | 14.7 k Ω | 11.3 k Ω | 4.02 k Ω |

Table 1. E-802.5x component substitution chart for voltage ranges and over-voltage recognition

More precise adjustments are not possible here, as the reference voltage is derived from the operating voltage, which can vary by about 1% from the nominal value. The same tolerance has to be taken into account regarding over-voltage recognition.

3.5 Additional Adjustment and Test Points

These adjustment elements and test points are not used during the standard calibration procedures.

Slew rate adjustment range too small, rise time too short:

install C401 (22-100 nF)

and / or change R407 (SMD, Standard 1 k Ω)

Proportional term too small, servo loop too slow:

increase P402 (potentiometer type Bourns 90°, Standard 50 k Ω)

increase R416 (SMD, Standard 470 Ω)

Proportional term too large:

decrease P402 (10 k Ω , 5 k Ω , Potentiometer Bourns, 90°, Standard 50 k Ω)

Integral term too small (settling time too long)

install C410 (wired RM 2,5, 22..100 nF)

Integral term too large:

decrease P403 (20 k Ω , 10 k Ω , Standard is 50 k Ω)

Servo-loop too slow, despite optimal setting

install P404 (20 k Ω)

adjust for best compromise of rise time and overshoot

Notch Filter, range of potentiometer too small:

see instructions for notch filter range setting

Test point A1, Slew Rate; Servo ON and OFF

set required rise time, watch PZT voltage and sensor values

Typical curve at positive input step:

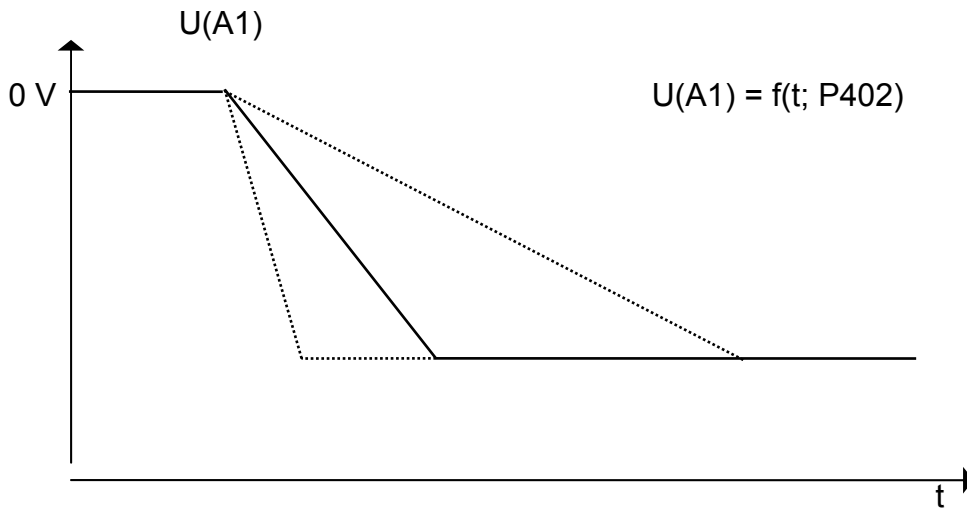

After the rise time the input voltage must be reached.

Note: This stage inverts the input signal.

Test point A2, comparison point, servoON only

After settling, this voltage must be zero.

Note: A permanent voltage indicates that somewhere in the servo-loop there is an undesirable limitation. (amplifier, PZT, sensor or controller)

Typical curve at positive input signal step.

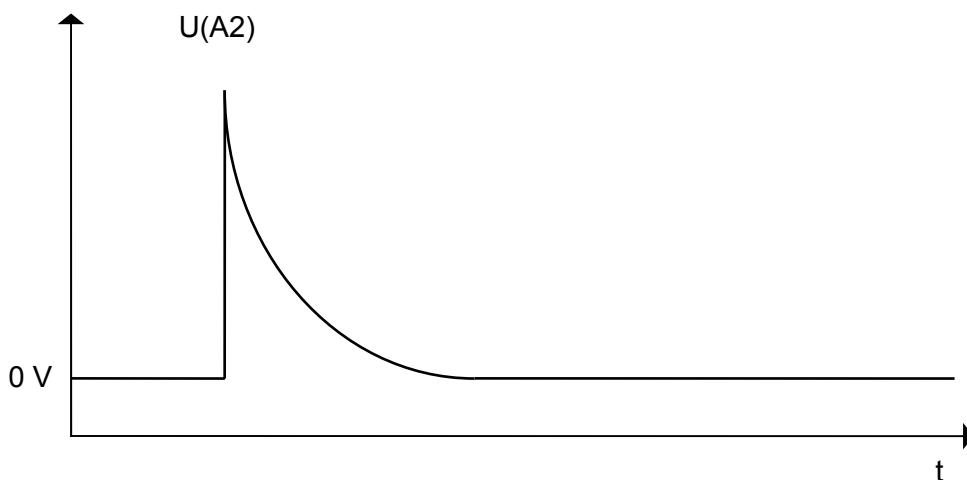

Test point A3, Integrator, Servo ON only

typical curve at (positive) input step

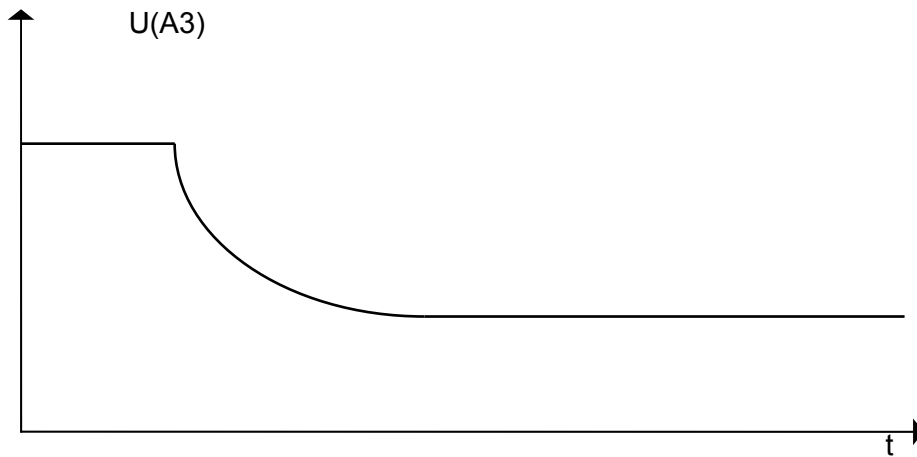

Test Criterion: Voltage within the limits

$$\text{max. } -9.5 \text{ V} < U(\text{A3}) < 12,5 \text{ V}$$

typ. allowed input range of the amplifier

Servo OFF: Voltage equals the input voltage

Test point A4, Controller, Servo ON only

Test Criterion: Sum signal of test point A3 and test point A2 (inverted)

Test point A5, Notch, Servo ON only

Time response at input step depends on setting, Example:

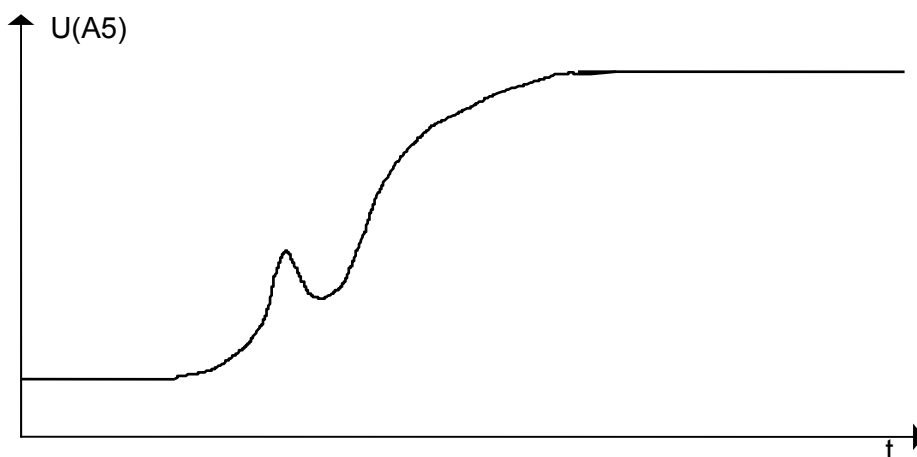

Test Criterion: Final value equals input signal

3.6 Pinouts

The connectors J1 and J2 of all E-802 versions are pin-compatible, except as noted.

Connector J1

| Pin | Signal | Meaning |
|-----|--------------|--|
| 1 | LED_K | Overflow LED, cathode (-), normally 0 V = overflow |
| 2 | LED_A | Overflow LED, anode (+), normally always +5 V |
| 3 | GND | 0 V |
| 4 | GND | 0 V |
| 5 | VC/EC | Set servo OFF/ON |
| 6 | VC/EC | Set servo OFF/ON |
| 7 | Actual value | Current position (0-10 V) |
| 8 | Actual value | Current position (0-10V) |
| 9 | VEE | -15 V |
| 10 | VEE | -15 V |

Connector J2

| Pin | Signal | Meaning |
|-----|--------------|--------------------------------------|
| 1 | CTRL_OUT | Servo-controlled output, -2 to +12 V |
| 2 | SERVO OFF/ON | switching |
| 3 | COMMAND | Target, 0-10 V |
| 4 | OFL | Overflow, TTL, active-low |
| 5 | VCC | +15 V |
| 6 | VCC | +15 V |
| 7 | VEE | -15 V |
| 8 | VEE | -15 V |
| 9 | GND | 0 V |
| 10 | GND | 0V |

3.7 Servo-Loop Calibration

Static servo-loop calibration makes it possible to accurately drive the PZT system to absolute positions in closed-loop mode with an external analog control signal ranging from 0 to +10 volts. This signal can either be input directly, or it can be generated by computer-control electronics in the system (e.g. E-816 Computer Interface and Command Interpreter).

Static servo calibration establishes the relationship between a sensor input of 10 V and the voltage necessary to drive the PZT to its nominal expansion.

Dynamic servo-loop calibration optimizes step response and suppresses resonance, overshoot, and oscillation (see section 3.8 beginning on page 26).

Dynamic performance of the PZT system is determined by the maximum output current of the amplifier and by the mechanical properties of the PZT-mechanics like moving mass, damping and resonant frequencies.

In order to match the circuitry and the mechanical characteristics to achieve the desired performance, the system has to be adjusted for both static and dynamic operations.

The full calibration and adjustment procedure includes adjustment of the zero point, sensor gain, slew rate and step response. All these basic adjustments are done in our lab before shipment.

If PI has sufficient information about your application, your PZT system will be shipped ready for operation. Only the zero point will have to be realigned from time to time to compensate for temperature changes. Further adjustments are not required as long as system components are not replaced or modified.

Since open-loop sensor zero and range adjustment does not involve the servo-control module, it is described in detail in the other manuals accompanying this system.

The PZT actuator has to be calibrated in conjunction with the individual device and submodule to which it is connected: both devices then belong together.

Replacement of either one or the other requires new calibration run to get the specified system accuracy.

3.7.1 Equipment Needed for Calibration

For adjustment of the zero-point, a voltmeter is required.

Static displacement calibration requires an external expansion gauge with 0.1 μm resolution and a precision voltmeter. A special extension adapter may be required if your installation does not allow access to the potentiometers that need to be adjusted while the unit is in operation.

Dynamic calibration procedures require an oscilloscope (a digital storage oscilloscope is recommended), frequency generator to output square and sine functions from 1 Hz to 1 kHz, an ohmmeter with a range from 0.1 to 100 k-ohm and, depending on the installation, a 32-pin extension adapter board to allow access to the trim potentiometers while the board is in operation.

If the system is set up for computer control, it may be possible to substitute the wave generators, D-to-A and A-to-D converters there for some of the equipment mentioned above.

3.7.2 Preparations

Mount the PZT actuator in exactly the same way and with the same load as during normal operations in the application.

3.7.3 Zero-Point Adjustment

Correct zero-point adjustment allows the PZT to be used within the full displacement range without reaching the output voltage limits of the amplifier.

A proper zero-point calibration ensures that in closed-loop operation the full output voltage swing of the amplifier can be used and prevents overflow conditions.

Procedure:

1. Adjust the sensor zero point while servo mode is OFF as described in the manual for the controller (desktop unit, module or OEM board) on which the E-802 is installed.
2. Set servo mode to SERVO ON and make sure that the control input voltage is set to the value (target position) which is to correspond to 0 V PZT operating voltage. Normally this control input voltage value is 0 V⁴.
3. Connect a voltmeter to the output socket for the PZT operating voltage.
4. Readjust the PZT operating voltage to 0 V using the ZERO potentiometer.

3.7.4 Static Gain Adjustment

The objective of the static servo-loop adjustment procedure is to ensure that the PZT actuator expands to its nominal expansion when the control signal input is 10 V.

Preparations: An adjustable voltage source from 0 to +10.0000 V and a displacement gauge with 0.1 μm resolution is needed⁵.

Procedure

1. Make sure that any DC-offset is set to zero or disabled (see main board manual).
2. Set SERVO ON mode.
3. Check whether the PZT oscillates. If it does, you can't miss hearing it, and dynamic gain adjustments have to be done prior to continuing with static gain adjustment.
4. Apply 0 V to the CONTROL INPUT.
5. Adjust the external position probe and set the expansion reading to zero.
6. Command a position equal to the nominal expansion (i.e. apply 10 V to the CONTROL INPUT). The external gauge should show the PZT at nominal expansion and the sensor monitor output should be 10 V.
7. To adjust the sensor monitor output to exactly 10.000 V use the GAIN Fine Adjust potentiometer on the servo submodule, E-802.5x.
8. To adjust the expansion without changing the sensor monitor output (servo-control is on!) use the gain adjustment potentiometer on the E-801.x sensor module.

Repeat the last steps several times until stable results are achieved.

⁴ In some cases, e.g. with the E-651 controller/amplifier for closed-loop bender actuators, the PZT operating voltage has to be 0 V if the control input voltage is -5 V.

⁵ With bender actuators a non-contact measuring method must be applied.

3.8 Dynamic Calibration

A summary of the equipment needed for calibration can be found in section 3.7.1 on page 24.

3.8.1 Finding Resonant Frequency and Setting Notch Filter

Evaluate the resonant frequency of the actuator while installed at the operation site. For this purpose a square wave is applied to the input with servo-control set to OFF (≈ 10 Hz, 1 Vpp, use DC offset 0.5 V if bipolar).

Connect the sensor monitor output with one channel of the oscilloscope and watch the step response. The resonant frequency of the system can be estimated by the induced oscillations. If, for example, the period of the oscillation is 3 ms, then the resonant frequency is $1/\text{period length}$ or $1/3 \text{ ms} = 0.33 \text{ kHz}$ or 330 Hz.

Based on this frequency, the dimensioning of the notch filter can be found in the tables in section 3.3, p. 19. Note that it may be necessary to add or change some components.

3.8.2 Step Response Optimization (Empirical Method)

Either this method or the calculation method, described in Section 3.8.3, can be used.

Standard Tuning

For dynamic operation, the step response of the mechanical system is important. The amount of damping and overshoot can be optimized by tuning the differential and integral term of the amplifier. Either the empirical or the calculating method can be used.

Procedure

1. Mount the PZT exactly as it will be operated.
2. Set Servo ON.
3. Use a square wave function generator and supply the input with a square wave of 5 Vpp (if bipolar, set DC offset to 2.5 V) and a frequency of 5 to 10 Hz.
4. Connect an oscilloscope to the monitor output.
5. Adjust P402 until resonant frequency becomes apparent.
6. Adjust P406 notch filter frequency until the oscillation amplitude becomes a minimum. (Do not confuse with P406 on an E-621).
7. Adjust P402 and P403, alternating to optimize step response.

The settling curve seen on the scope could look like one of the following:

Case 1: Large overshoot, unstable

Case 2: Optimal

Case 3: Settling time too long

Sensor Monitor Signal:

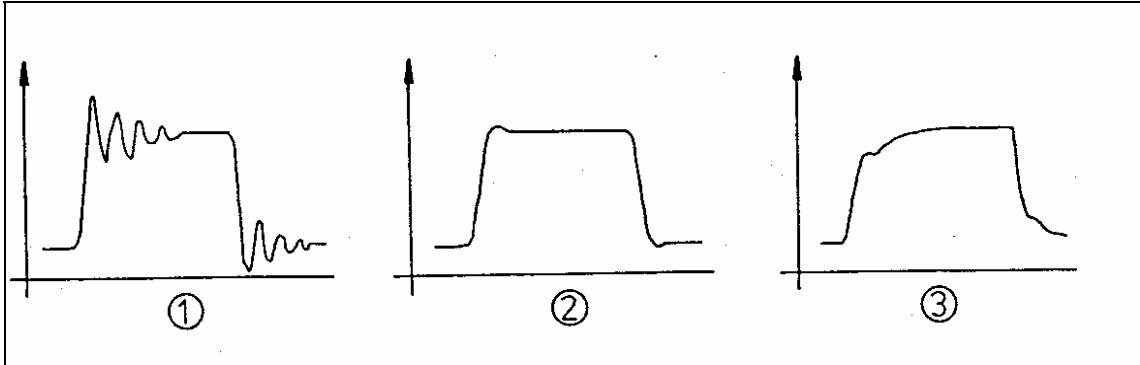

Dwg.: PZTRESP.BMP

Fine Tuning

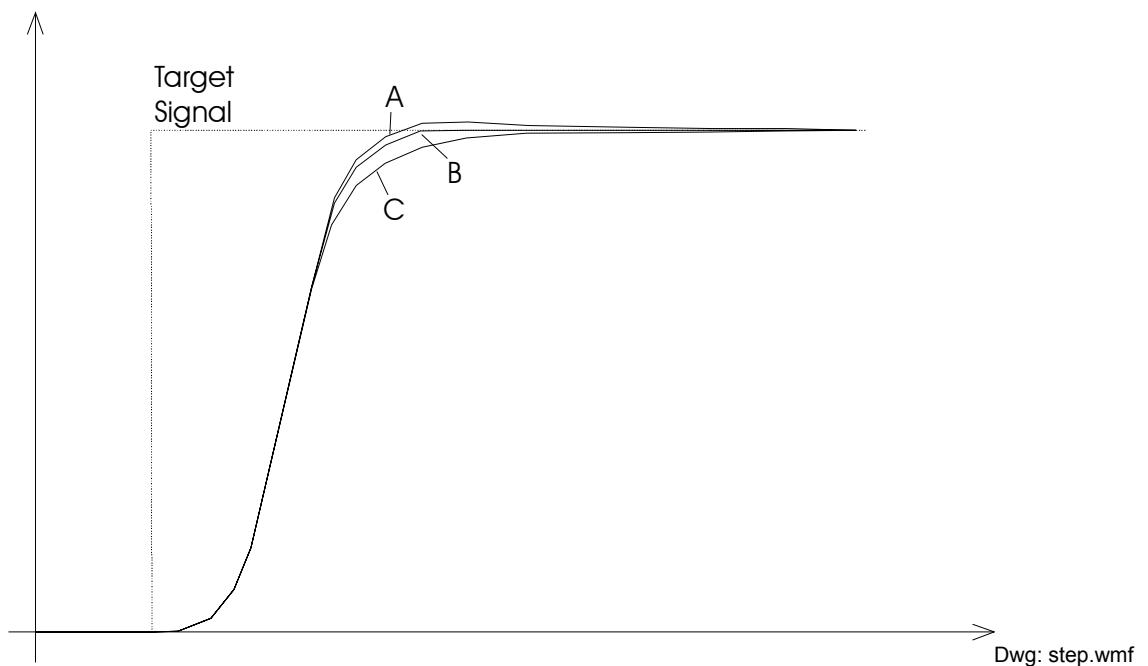

The objective of the drift fine tuning is curve B of the diagram. Because the curve is exaggerated, a high-resolution oscilloscope (12-14 bits) is required as well as a precise voltage generator.

First, adjust the step response without overshoot. Using P405 curve shapes A, B and C can be attained. If the overshoot can not be eliminated by using P405, the loop gain has to be reduced.

The result may be different at rising and falling edges, so a compromise has to be found.

3.8.3 Step-Response Optimization (Calculation Method)

Either this method or the empirical method, described in Section 3.8.2, can be used.

Servo-loop parameters depend on each and every component used in the system. Amplifier, PZT actuator and sensor have to be treated as a complete system, and the best way to determine the system servo parameters is the use of a simulation program.

If no simulation program is available, typical assumptions can be made in order to get stable servo parameters—not optimized, but good enough to work with.

Proportional term: $K_p = 0.3$

Integration time: $T_I = \frac{1}{2\pi f_{res}}$

Example: $f_{res} = 330 \text{ Hz} \rightarrow T_I = 0.48 \text{ ms}$

Note: If the PZT resonant frequency is above 1 kHz, the system bandwidth is limited by the amplifier and the sensor. In no case should a higher frequency be used.

3.8.4 Sizing Components

$$P_{402} = K_p \cdot 27400\Omega - 470\Omega;$$

$$P_{403} = \frac{T_I}{C_{410} + C_{411}} - 470\Omega; [T_I] = s; C_{410} = 0F; C_{411} = 22 \cdot 10^{-9} F;$$

Example: $K_p = 0.3 \rightarrow P_{402} = 7.75 \text{ k}\Omega;$
 $T_I = 0.48 \text{ ms} \rightarrow P_{403} = 21.35 \text{ k}\Omega;$

3.8.5 Applying Calculated Values in the Circuit

Case 1: If a software simulation run has already determined the optimized values, these values can be set immediately using the corresponding potentiometers.

Case 2: The following procedure has to be used if the servo parameters are derived from arbitrary values:

1. Set potentiometer P401 (slew rate limitation) to CCW hard stop.
2. Set P402 (p-term) to starting value using an ohmmeter.
3. Set P403 (i-term) to a value of 130% of the calculated value (add 30% to the calculated value).
4. Power up the device and set SERVO ON. If you hear oscillation noise, set SERVO OFF immediately. Verify all values you have set.
5. Apply a square wave signal (10 Hz, 10 Vpp, 5 V Offset) to the input.

6. Turn potentiometer P403 (i-term) CW until a significant overshoot can be seen (2 to 5%).
7. Adjust P406 (notch filter) so that resonance effects and overshooting are optimally damped.
8. Depending on the application, set P403 either for optimized settling or to allow an overshoot of 5 to 10 %. The latter choice provides a larger bandwidth.
9. Turn P401 (slew rate limitation) CW until the wobble comes to a minimum without increasing the rise time significantly.
10. Apply a sine wave with variable frequency, 10 Vpp, 5 V offset. Check the sensor reading for amplitude and signal shape starting at 10 Hz up to the resonant frequency. If needed, repeat steps 8 and 9. If the bandwidth is too small, increase the i-term. (This also increases the overshoot amplitude for a step response.) If signal distortions are already noticeable well below the resonant frequency, decrease the i-term.

