

M-126 High-Resolution Translation Stage

Compact Linear Stage with Crossed Roller Bearings



M-126.CG1 translation stage with compact DC motor/gearhead

- **Min. Incremental Motion to 0.1 μm (3.5 nm Resolution)**
- **Repeatability to 0.1 μm**
- **Velocity to 50 mm/s**
- **Travel Ranges 20 and 25 mm**
- **Manual, DC-Servo and Stepper-Motor Drives**
- **ActiveDrive™ Option**
- **Crossed Roller Bearings**
- **Ball screw and Leadscrew Versions**
- **XY and XYZ Combinations**
- **Direction-Sensing Reference Switch**
- **Variety of Cost-Effective Motion Controllers**

M-126 micropositioning systems are compact, high-precision translation stages with preloaded leadscrew and ballscrew drives for excellent resolution and repeatability. All models are equipped with precision crossed roller bearings providing straightness of travel of better than 2 μm .

Five motorized versions are available: M-126.CG1 utilizes a compact closed-loop DC motor with shaft-mounted high-resolution position encoder and a precision gearhead providing 0.1 μm minimum incremental motion, M-126.DG1 is equipped with a larger motor than M-126.CG1 and provides higher velocity. The M-126.2S1 stepper motor version has a 2-phase stepper motor that provides a minimum incremental motion of 0.1 μm (controller depending).

Higher Speed with ActiveDrive™ and Ballscrews

The top-of-the-line M-126.PD2 is equipped with a low friction ballscrew and provides ve-

locities to 50 mm/sec. Model M-126.PD1 features a leadscrew and is recommended for lower speeds to 15 mm/sec and/or duty cycle applications. Both versions boast the high-performance ActiveDrive™. PI's ActiveDrive™ design, features a high-efficiency PWM (pulse width modulation) servo-amplifier mounted side-by-side with the DC motor and offers several advantages:

- **Increased efficiency by eliminating power losses between the amplifier and motor**
- **Reduced cost of ownership and improved reliability because no external driver is required**
- **Elimination of PWM amplifier noise radiation by mounting the amplifier and motor together in a single electrically shielded case**

Limit and Reference Switches

For the protection of your equipment, non-contact Hall-effect limit and reference

switches are installed. The direction-sensing reference switch supports advanced automation applications with high precision.

XY and XYZ Combinations

All stages can be cross-stacked and combined with the M-125.90 Z-axis mounting bracket to provide multi-axis motion.

Notes

For adapters, bracket, etc. see p. 4-90 ff.

Ordering Information

M-126.CG1
Translation Stage, 25 mm, Compact DC Motor Gearhead

M-126.DG1
Translation Stage, 25 mm, DC Motor Gearhead

M-126.PD1
Translation Stage, 25 mm, ActiveDrive™ DC Motor (includes 24 V power supply)

M-126.PD2
Translation Stage, 20 mm, ActiveDrive™ DC Motor, Ballscrew (includes 24 V power supply)

M-126.2S1
Translation Stage, 25 mm, 2-Phase Stepper Motor

M-126.M0
Translation Stage, 25 mm, Manual Drive, Leadscrew

M-125.90
Z-axis Mounting Bracket for Vertical Mount of M-126 Stages

M-126.80
Adapter Plate for Honeycomb Tables

Ask about custom designs!

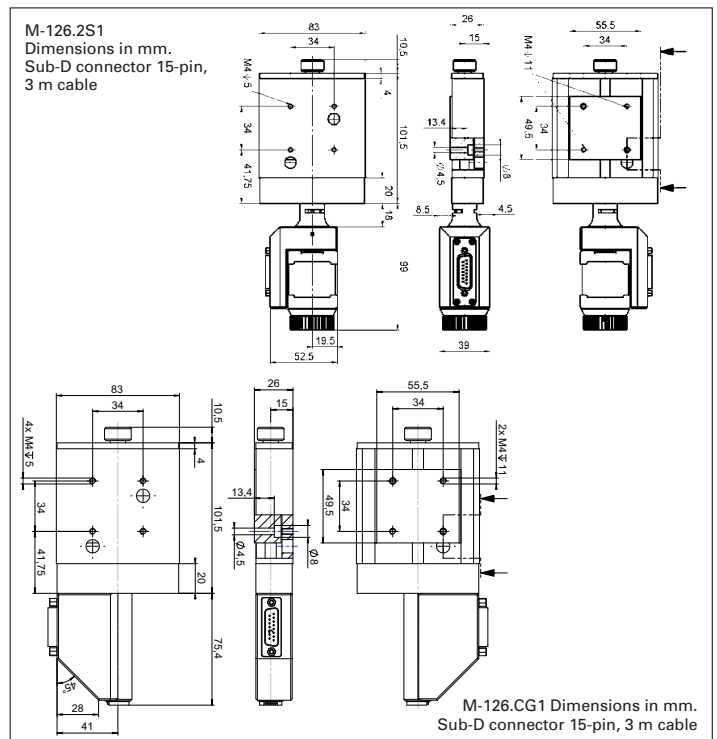

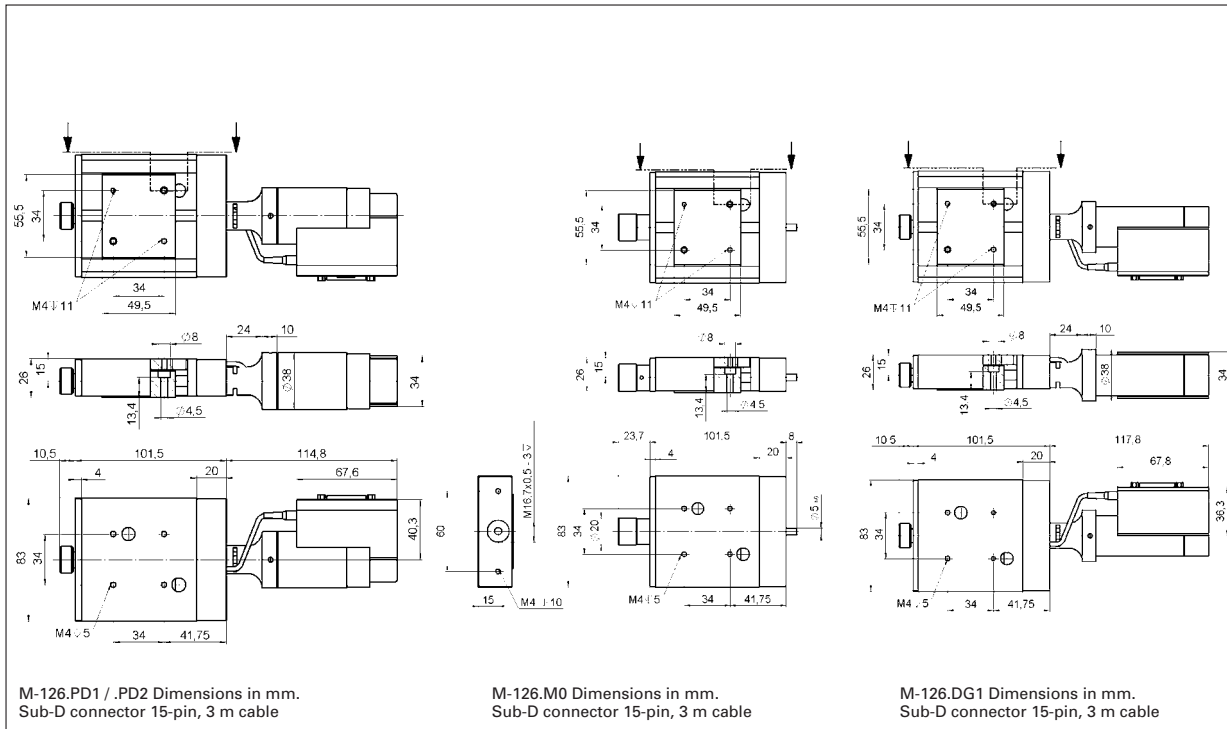

Technical Data

Model	M-126.M0	M-126.CG1	M-126.DG1	M-126.PD1	M-126.PD2	M-126.2S1	Units
Active Axes	X	X	X	X	X	X	
Motion and positioning							
Travel range	25	25	25	25	20	25	mm
Integrated sensor	–	Rotary encoder	Rotary encoder	Rotary encoder	Rotary encoder	–	
Sensor resolution	–	2048	2000	4000	4000	–	Cts./rev
Design resolution	–	0.0035	0.0085	0.125	0.25	0.08**	µm
Min. incremental motion	1	0.1	0.1	0.25	0.5	0.1**	µm
Unidirectional repeatability	–	0.2	0.1	0.1	0.3	0.1**	µm
Bidirectional repeatability	–	2	1	1	1	1**	µm
Accuracy	–	2.5	2.5	2.5	2.5	2.5	µm
Pitch / Yaw	±50	±50	±50	±50	±50	±50	µrad
Straightness / Flatness	2	2	2	2	2	2	µm
Max. velocity	–	0.7	1.5	15*	50	6**	mm/s
Origin repeatability	–	1	1	1	1	1	µm
Mechanical properties							
Drive Screw	Leadscrew	Leadscrew	Leadscrew	Leadscrew	Recirculating ballscrew	Leadscrew	
Thread pitch	0.5	0.5	0.5	0.5	1	0.5	mm
Gear ratio	–	69.12:1	(28/12) ^{±0.1} ~ 29.6:1	–	–	–	
Motor resolution	–	–	–	–	–	6400**	steps/rev.
Max. load	200	200	200	200	200	200	N
Max. push / pull force	50 / 50	40 / 40	50 / 50	50 / 50	40 / 40	50 / 50	N
Max. lateral force	100	100	100	100	100	100	N
Drive properties							
Motor type	–	DC Motor, gearhead	DC Motor, gearhead	ActiveDrive™ DC Motor	ActiveDrive™ DC Motor	2-phase stepper motor	
Operating voltage	–	0 to ±12	0 to ±12	24 (PWM)	24 (PWM)	24	V
Electrical power	–	2	3	30	30		W
Limit and reference switches	–	Hall-effect	Hall-effect	Hall-effect	Hall-effect	Hall-effect	
Miscellaneous							
Operating temperature range	-20 to +65	-20 to +65	-20 to +65	-20 to +65	-20 to +65	-20 to +65	°C
Material	Aluminum, steel	Aluminum, steel	Aluminum, steel	Aluminum, steel	Aluminum, steel	Aluminum, steel	
Mass	0.6	0.8	0.9	0.9	0.9	1	kg
Recommended controller/driver	–	C-863 single-axis C-843 PCI board, for up to 4 axes	C-863 single-axis C-843 PCI board, for up to 4 axes	C-863 single-axis C-843 PCI board, for up to 4 axes	C-863 single-axis (p. 4-114) C-843 PCI board (p. 4-120), for up to 4 axes	C-663 single-axis (p. 4-112)	

*Max. recommended velocity

**2-phase stepper motor, 24 V chopper voltage, max. 0.8 A/phase, 400 full steps/rev., motor resolution with C-663 stepper motor controller